



New Product Category Is Here – Greet DYNASET Vacuum Products

New Product Category Is Here – Greet DYNASET Vacuum Products

January of 2021 is here, and it brings great news to the field of machinery! We launch a new product category called Vacuum. The products of this category are specified to airflow and they can be used for vacuum and for air blow applications. The products of this category get their operating power from hydraulics as all our products do.



The first application of the Vacuum product category is the HRVB Hydraulic Recycling Vacuum Bucket. This bucket is a game-changer for waste sorting in the fields of property management, demolition, and construction.

Briefly, this category holds products that get their airflow ability from our new DYNASET HCF Hydraulic Centrifugal Fan. These fans can be used for suction as vacuum cleaners or for air blowing like leaf blowers. Although it is important to notice that these fans are used with machinery, so they are much more powerful than hand tools like leaf blowers.

Compact-sized HCF Hydraulic Centrifugal Fans get their operating power from a hydraulic motor which spins a specially made and engineered fan blade that is inside the unit. This high-rpm blade makes the airflow through the unit. The principle of the airflow is quite simple: another end of the unit is an intake, and another is an output.

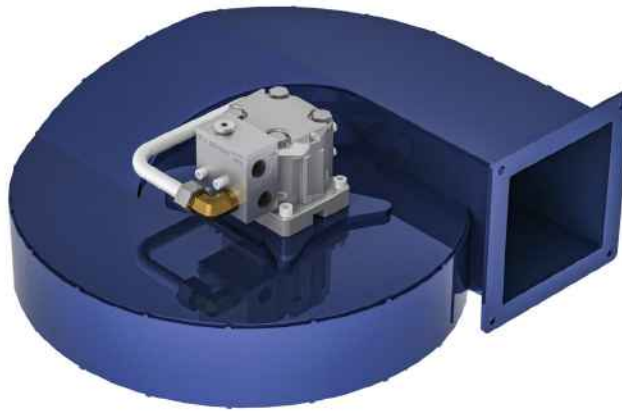

DYNASET HCF Hydraulic Centrifugal Fan is the heart of the new product category. The fan is possible to install into tight places because it is cooled by the air which flows through it. The new fan has three different models HCF-800-40, HCF-1500-50, and HCF-3400-90.

In other words, the intake can be used for vacuum applications, like powerful mobile vacuum cleaning machines and vacuum trucks for example. Meanwhile, the output can be used for air blowing applications, like cleaning machinery of dust with air blow or like for air flushing of railways and tramways. The first application of this fan is DYNASET HRVB Hydraulic Recycling Vacuum Bucket.

Brand New DYNASET HRVB Hydraulic Recycling Vacuum Bucket Makes Waste Collecting Much Easier!

DYNASET HRVB Hydraulic Recycling Vacuum Bucket is an excavator bucket that is specially designed to bring easiness to worksites' cleaning and recycling tasks. This special bucket is a combination of an excavator bucket and a vacuum cleaner. On top of that, this bucket can also be used as an air blower.



HRVB Hydraulic Recycling Vacuum Bucket is a combination of an excavator bucket and a vacuum cleaner. It can be used for fast and efficient waste sorting and for worksite cleaning for example.

Especially in demolition sites, the smaller and lighter pieces of debris should be separated from the rubble piles because that way the waste treatment is much easier and cheaper. That is because commonly waste treatment is priced by weight.

And why not use a regular bucket? With the HRVB less sand and rocks end up in the waste containers. So the waste container won't include that much of a dead weight that consists of rocks and sand. Another way to do the sorting is by legwork, but that is a much slower way to do site cleaning than with an excavator with this bucket. In other words, using this bucket is much more cost-effective than traditional ways to collect waste.



This new bucket can be used for worksite cleaning like a vacuum cleaner. Packaging plastics and such are often trying to spread to the environment because of the wind. With this bucket, daily environment cleaning is fast and possible.

Fast Sorting During the Demolition

With this bucket, it is fast to collect any types of wool, plastics, pieces of wood, and light expanded clay aggregate (LECA). It is even possible to collect specific materials during the demolition work. For example, the bucket can be used for collecting the wool from the structures right when they are exposed during the demolition. That way wool can be sorted before it ends up in rubble piles.



With HRVB Hydraulic Recycling Vacuum Bucket it is possible to sort demolition waste better which is a more cost-effective way to do site cleaning. For example, light expanded clay aggregate, or LECA, can be sorted out from the rubble or directly from the structures when LECA is exposed.

For Daily Use on Worksites

In construction sites, HRVB Hydraulic Recycling Vacuum Bucket can be used for daily clean up. Construction sites are often large areas and because of the wind, the packaging plastics and such try to spread to the environment. With the bucket, one excavator and operator can do the daily clean-up much faster than a bunch of workers.

How Does It Work?

First of all, the bucket can be equipped with a quick coupler so you can pick it up with your excavator. The hydraulics of the bucket includes four lines. Two of them are the pressure and tank lines, which transfer the hydraulic power to the hydraulic motor of the bucket which spins the fan blade. Because the hydraulic oil flow is powering up the operation of the bucket, the blade RPM, or power of the suction, is continuously adjustable via hydraulic oil flow. Two other lines are used for the hatch controls. This means that the operator can adjust the size of the suction port with the hatch.

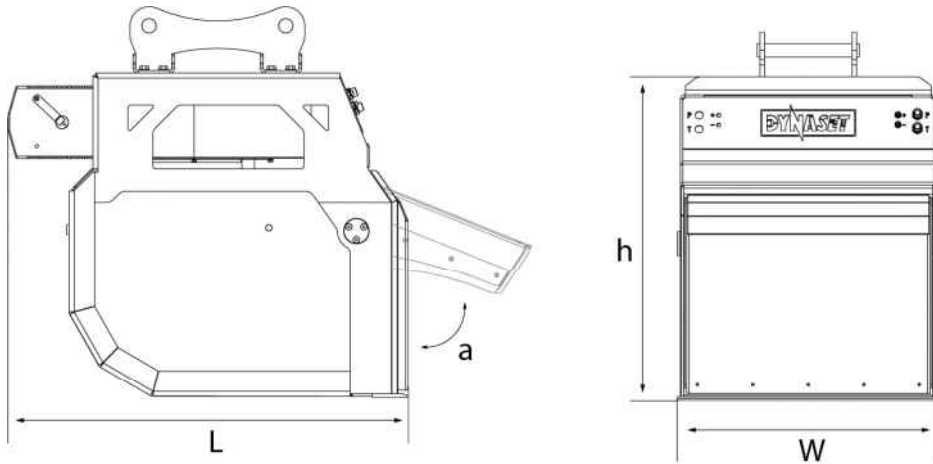

Dimensions: Length (L) 1314 mm, Opening of the Hatch (a) 76,3°, Height (h) 1031 mm, Width (W) 854 mm, Weight 450 kg.

The bucket also has a port for an auxiliary vacuum hose. This port can be found from the backside of the bucket. This port can be used for vacuum cleaning that is done by legwork and a hose. So, if the cleaning task needs even more precise vacuum cleaning, the hose can be used for these tasks. The recommended diameter of this hose is 80-100 millimeters which ensure fast vacuum cleaning in tight places. For example, with the bucket's auxiliary vacuum hose it is possible to empty stormwater drainages from the sand. So with this port, the user can do vacuum cleaning tasks which decreases the need for vacuum trucks in certain tasks like stormwater drainage emptying tasks.

Air Blowing Ability As a Tool

But what about the air blowing applications? The air blow port is on the same side as the auxiliary vacuum port. Basically, the air is blowing through this port all the time when the bucket's fan is running. But if you want to use the bucket for air blowing you just need to flip the bucket with a rotator to another way around and you are ready to blow for example leaves, trash, and snow from your way. This application is in use at the tramway of Tampere, Finland as we speak.



At the tramways of Tampere, the HRVB Hydraulic Recycling Vacuum Bucket is used for daily maintenance. The air-blowing ability is used for tramway cleaning.

What Else Does the New Category Bring to The Table?

The heart of the new product category, HFC Hydraulic Centrifugal Fan, can be a solution for many ventilation, air blow, and vacuum cleaning applications. Because the fan is driven by a hydraulic motor, it can be fitted into tight spaces. That's because cooling of the unit is done by the air that flows through the unit.